



MACHINE AGE

SPECIFICATION SHEET



2S2WG7/41/E15/60WINC

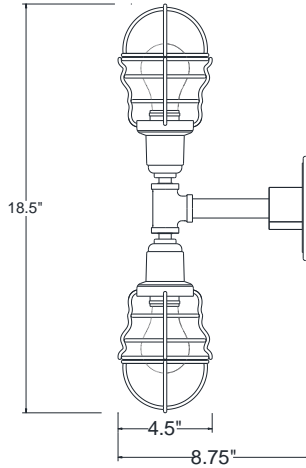

MODEL: 2S2WG7

PREPARED BY: _____

TYPE: _____

JOB NAME: _____

DATE: _____

CERTIFICATION: UL LISTED

FINISH – Five stage pretreatment process, coated with a lead free TGI C polyester powder coat finish. White is standard inside reflectors, *some finish options excluded. See color chart below for color options (unless specified). Some finish options are not available for certain fixtures. Custom colors and Marine options are available upon request. **Finishes #14PN, 19, 20, 20PB, 20SB, 21, 22, 23, 39, 40, 57, 58, 88 do not apply to this fixture.**

LAMP HOLDERS – Accommodates **Incandescent/LED** bulb – medium base porcelain socket, copper shell with nickel plate, rated 250v, 660W.

MOUNTING – Wall mount only. Rated for dry location.

REFLECTOR – Spun from heavy gauge 1100-0 aluminum, ranging in thickness from .050 to .125. Steel wire grill, steel fittings and cast aluminum backplate.

MODEL #	FINISH	LIGHT SOURCE				MOUNTING OPTIONS	ACCESSORIES
		INC	CF*	MH*	LED		
2S2WG7	SEE THE FINISH OPTION CHART ON THE WEBSITE AT THE BOTTOM OF THE PAGE UNDER "PRODUCT INFORMATION".	2-60W	N/A	N/A	N/A	WALL MOUNT	N/A

* same finish color inside and out.
* remote ballast / driver.

.SUBJECT TO MODIFICATION WITHOUT NOTICE.



BASELITE CORPORATION
12260 EAST END AVE.
CHINO, CA 91710

PH: 877-999-1990
WEB: WWW.BASELITE.COM
EMAIL: SALES@BASELITE.COM

