

WAREHOUSE SHADES

PREPARED BY: _____

TYPE: _____

JOB NAME: _____

DATE: _____

CERTIFICATION: UL LISTED

MODEL#	D"	H"
W508	8	6
W512	12	8
W514	14	9
W516	16	9

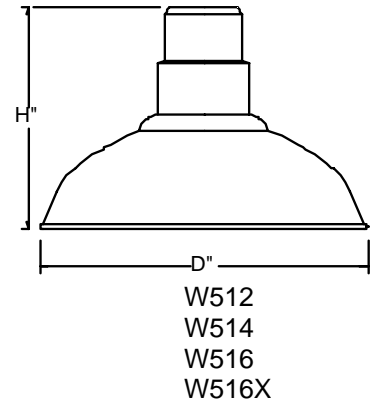
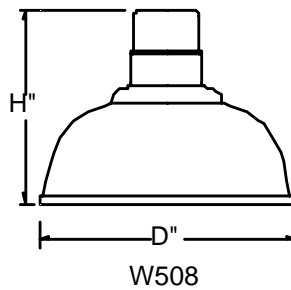

FINISH-Five stage pretreatment process, coated with a lead free TGI C polyester powder coat finish. White is standard inside reflectors, Except #49-Galvanized, #62-Anodized Bronze and #63-Iron Rust, Unless specified. Custom colors and Marine are available upon request.

MOUNTING- 1/2" or 3/4" tapped hub is supplied. Top or side mount available. Fixtures are pre-wired with 48" or 96" leads. Available with cord or stem sets.

REFLECTOR- Spun from heavy gauge 1100-0 aluminum, ranging in thickness from .050 to .125. Galvanized is from 20 gauge sheets. Copper is spun from .040 gauge and 110 soft alloy.

LAMP HOLDERS- Accommodates **Incandescent** medium base porcelain socket, copper shell with nicked plate, rated 250V, 660W. **Compact Fluorescent** 4 pin heat resistant thermoplastic socket accommodates 26/32W (Gx24q-3 base) and 42W (Gx24q-4 base). Twist lock design provides for vibration and earthquake resistance, rated 75W, 600V. **High Intensity Discharge (H.I.D.)** medium base, 4KV pulse start socket, rated 660W/600V. **LED**. A minimum of 60,000 hours to 100,000 expected life depending on installation location and ambient temperature.

MODEL#	FINISH		LIGHT SOURCE				MOUNTING OPT.
			INC	CF ¹	HID ¹	LED ¹	
W508	40-copper w/ coat	52-patina	100W	26W	35W	10W	-Arm extension -Post Mts & Pole -Stem -Cord ² -Cable & Chain -Hub
W512	41-black 42-dr. green 43-red 44-white	53-rust 54-stucco 55-sage 57-polish alum w/ coat					
W514	45-med. blue 46-yellow	58-satin alum. clear coat	150W	32W	50W	20W	
W516	48-polish alum. 49-galvanized	59-coppertone 60-canal green	200W	42W	70W	100W	
W516X	50-navy blue 51-arch. Bronze	61-anod. charcoal 62-anod. bronze 63-iron rust					

¹REMOTE BALLAST/DRIVER

²INC MAX WATTAGE 150W

CALL FACTORY FOR HIGHER WATTAGE



PHONE: 877-999-1990
FAX: 877-999-1955

12260 EAST END AVE. CHINO, CA 91710

WAREHOUSE SHADES

PREPARED BY: _____

TYPE: _____

JOB NAME: _____

DATE: _____

CERTIFICATION: UL LISTED

MODEL#	D"	H"
W518	18	9
W520	20	10
W524	24	16
W527	27	16

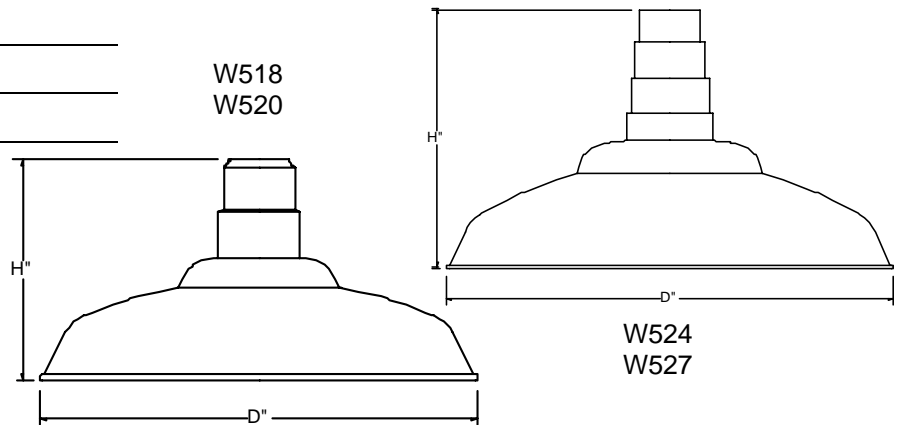

FINISH-Five stage pretreatment process, coated with a lead free TGI C polyester powder coat finish. White is standard inside reflectors, Except #49-Galvanized, #62-Anodized Bronze and #63-Iron Rust, Unless specified. Custom colors and Marine are available upon request.

MOUNTING- 1/2" or 3/4" tapped hub is supplied. Top or side mount available. Fixtures are pre-wired with 48" or 96" leads. Available with cord or stem sets.

REFLECTOR- Spun from heavy gauge 1100-0 aluminum, ranging in thickness from .050 to .125. Galvanized is from 20 gauge sheets. Copper is spun from .040 gauge and 110 soft alloy.

LAMP HOLDERS- Accommodates **Incandescent** medium base porcelain socket, copper shell with nicked plate, rated 250V, 660W. **Compact Fluorescent** 4 pin heat resistant thermoplastic socket accommodates 26/32W (Gx24q-3 base) and 42W (Gx24q-4 base). Twist lock design provides for vibration and earthquake resistance, rated 75W, 600V. **High Intensity Discharge (H.I.D.)** medium base, 4KV pulse start socket, rated 660W/600V. **LED**. A minimum of 60,000 hours to 100,000 expected life depending on installation location and ambient temperature.

MODEL#	FINISH		LIGHT SOURCE				MOUNTING OPT.
			INC	CF ¹	HID ¹	LED ¹	
W518	40-copper w/ coat	52-patina	300W	26W,	35W	57W	-Arm extension -Post Mts & Pole -Stem -Cord ² -Cable & Chain -Hub
	41-black	53-rust		32W,			
W520	42-dr. green	54-stucco	1X26W	50W	79W		
	43-red	55-sage				1X32W	
W524	44-white	57-polish alum w/ coat	1X42W	70W	93W		
	45-med. blue	58-satin alum. clear coat				100W	
W527	46-yellow	59-coppertone	2X26W	93W			
	48-polish alum.	60-canal green	2X32W				
	49-galvanized	61-anod. charcoal	2X42W				
	50-navy blue	62-anod. bronze					
	51-arch. Bronze	63-iron rust					

¹REMOTE BALLAST

²INC MAX WATTAGE 150W

CALL FACTORY FOR HIGHER WATTAGE

PHONE: 877-999-1990

FAX: 877-999-1955



12260 EAST END AVE. CHINO, CA 91710

MADE IN

