

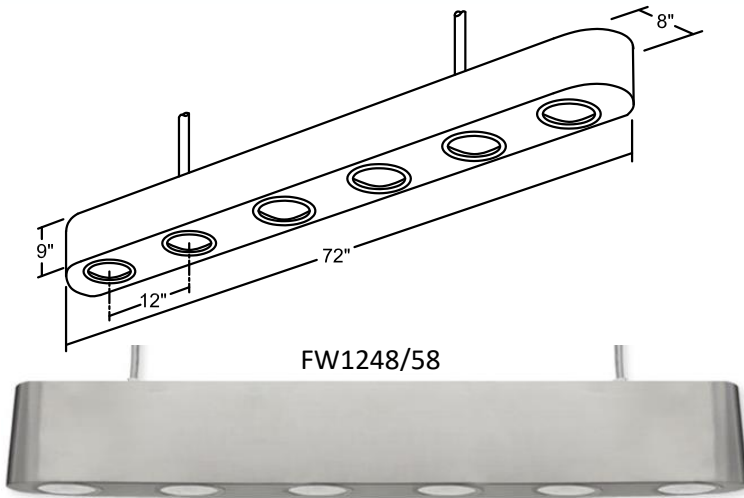

FOOD WARMER



MODEL: FW1272

PREPARED BY: _____

TYPE: _____

JOB NAME: _____

DATE: _____

CERTIFICATION: UL Listed NSF Approved

FINISH – Five stage pretreatment process, coated with a lead free TGI C polyester powder coat finish. White is standard inside reflectors. See color chart below for color options. Some finish options are not available for certain fixtures. Custom color options are available upon request.

LAMP – Food Warmer – medium base porcelain socket, copper shell with nickel plate, rated 250v, 660W. 250 Watt Infrared R40 Bulb. Available in clear or red, shatter proof coated or non-coated.

Decorative Applications – Can accommodate LED, Compact Fluorescent, Incandescent, or High Intensity Discharge (H.I.D.).

MOUNTING – 3/4" Stem with canopy, customizable length

FIXTURE – Heavy gauge 1100-0 aluminum, ranging in thickness from .050 to .125.

MODEL #	FINISH	LIGHT SOURCE				MOUNTING OPTIONS	ACCESSORIES
		INC					
FW1272 ²	21P, 41, 42, 43, 44, 45, 48*, 49*, 50, 51, 52, 53, 57*, 58*, 59, 61*, 62*, 70*, 71*, 74, 75, 76, 79, 81, 84*, 87, 90, 93, 95, 97	250WRC 250WCC 250WRU ¹ 250WCU ¹				STXX	TSC TSF ² TSR

* same finish color inside and out. 1. not NSF approved. 2. not available with 375 watt bulb. .SUBJECT TO MODIFICATION WITHOUT NOTICE.



BASELITE CORPORATION
12260 EAST END AVE.
CHINO, CA 91710

PH: 877-999-1990
WEB: WWW.BASELITE.COM
EMAIL: SALES@BASELITE.COM

